

**STANDARD:**

- Investment Casting Body & Cap
- 200PSI
- Wheel Handle Operation
- All Kind of Screws Available
- Locking Device Handle Available
- Design Standard:ASME B16.34
- Wall Thickness:ASME B16.34,GB 12224
- Inspection Standard:API598



MJ1010

Technical Date			
Test Pressure	Shell Test	2.0	MPA
	Tightness Test	2.5	
	Gas-Tightness Test	0.8	
Max Working temperature		-40°C~+250°C	
Applicable Medium:Water,Oil,Gas,Acid			

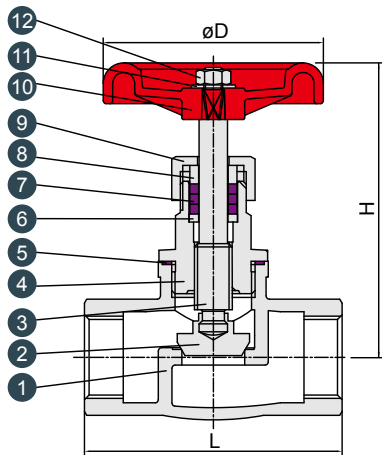

No.	PART NAME	MATERIAL	
1	Body	CF8M	CF8
2	Disc	CF8M	CF8
3	Stem	SS316	SS304
4	Bonnet	CF8M	CF8
5	Body Gasket	PTFE	
6	Washer	SS304	
7	Packing	PTFE	
8	Packing Sleeve	SS304	
9	Gland	SS304	
10	Hand Wheel	Aluminum	
11	Nut	SS304	
12	Plain Washer	Aluminum	

Unit:mm

SIZE	d	L	H	D
1/4"	10	65	92	66
3/8"	10	65	92	66
1/2"	15	63	92	66
3/4"	20	77	98	66
1"	25	88	115	73
1 1/4"	32	102	125	95
1 1/2"	38	118	140	105
2"	48	137	150	105