

**STANDARD:**

- Investment Casting Body & Cap
- 800PSI PN40
- 2-PC Design Full Port
- All Kind of Thread Standard Available
- Design Standard:ASME B16.34
- Inspection Standard:API598

Technical Data			
Test Pressure	Shell Test	3.0	MPA
	Tightness Test	3.5	
	Gas-Tightness Test	0.8	
Max Working temperature		-40°C~+250°C	
Applicable Medium:Water,Oil,Gas,Acid			



MC1030

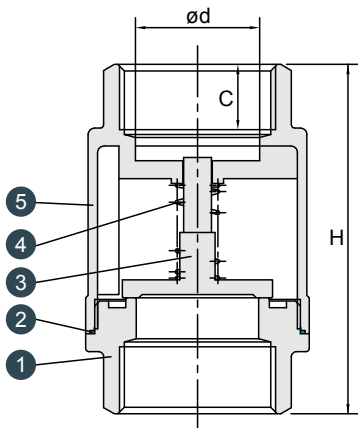

No.	PART NAME	MATERIAL	
		CF8M	CF8
1	Cap	CF8M	CF8
2	Gasket	CF8M	CF8
3	Disc	SS316	SS304
4	Spring	CF8M	CF8
5	Body	CF8M	CF8

Unit:mm

SIZE	d	H	C
1/4"	10	58	11
3/8"	10	58	11
1/2"	15	60	11
3/4"	20	68	14
1"	25	82	15.5
1¼"	32	92	19.5
1½"	38	100	20
2"	48	109	21.5